

30 Hz – 100 KHz RE101 Loop Antenna

1. Introduction

The TBRE101 is a passive receiving loop antenna used in MIL-STD-461G RE101 testing to measure radiated emissions from electronic equipment and subsystems, including electrical cable interfaces for defense applications.

The TBRE101 is used to measure low frequency magnetic field emissions 7cm from all sides of the DUT. The test covers the frequency range of 30 Hz to 100 KHz. Section 5.17 of the MIL-STD-461G specifies the test setup and measurement procedure.

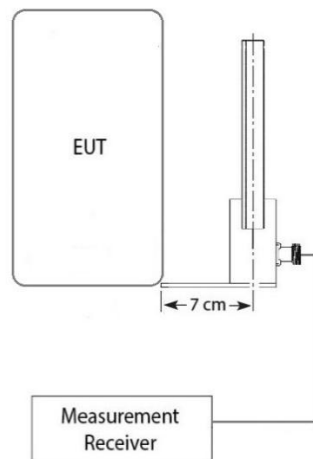

TBRE101 Typical Test Setup

The TBRE101 consists of a 13.3 cm diameter coil with 36 turns of 7 strand 41 AWG Litz wire inside a shield. The DC resistance of the loop winding is 10 ohms. The loop receives magnetic field radiation normal to the contained plane and creates a voltage signal proportional to the intensity of the B-field/H-field radiation at the loop's output port.

A TekBox TBCCP1-2K70 coaxial RF current monitoring probe (transducer) with a flat transfer impedance of 0 dB Ω (1V/A) from 9 kHz to 30 MHz when loaded with 50 Ω is an optional accessory for calibration purposes.

30 Hz – 100 KHz RE101 Loop Antenna

2. Technical specifications

Antenna type	Receiving Loop
Frequency range	30 Hz–100 KHz (usable frequency range: 10 Hz-1 MHz)
Standards	MIL-STD-461G / RE101
Loop diameter	13.3 cm
Loop construction	36 turns of 7 strand 41 AWG Litz wire
DC resistance of the loop coil	10 Ω (Nominal)
Self inductance of the loop coil	385 μ H
Output connector	N-female, 50 Ω
Antenna conversion factor	Within ± 3 dB compared to the theoretical validation factor for standard RE101 loop in MIL-STD-461G
Mechanical Dimensions	L x W x H: 10.62 cm x 15.2 cm x 19.1 cm (4.18" x 5.98" x 7.52")
Weight	0.5 kg (1.1 lbs)

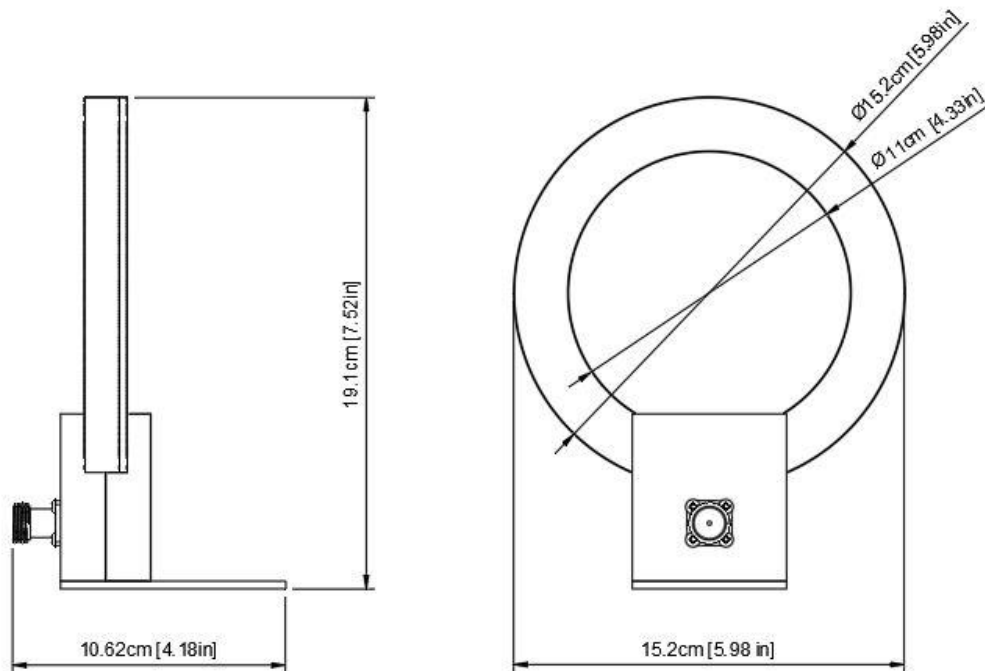

TBRE101 receiving loop dimensions

30 Hz – 100 KHz RE101 Loop Antenna

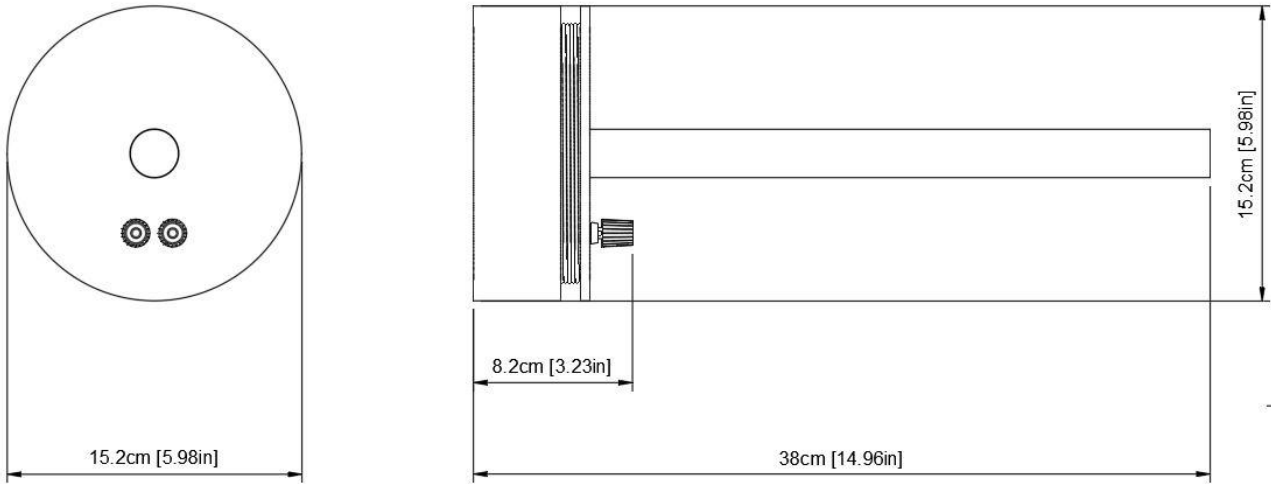

Accessory TBRS101-TX radiating loop dimensions

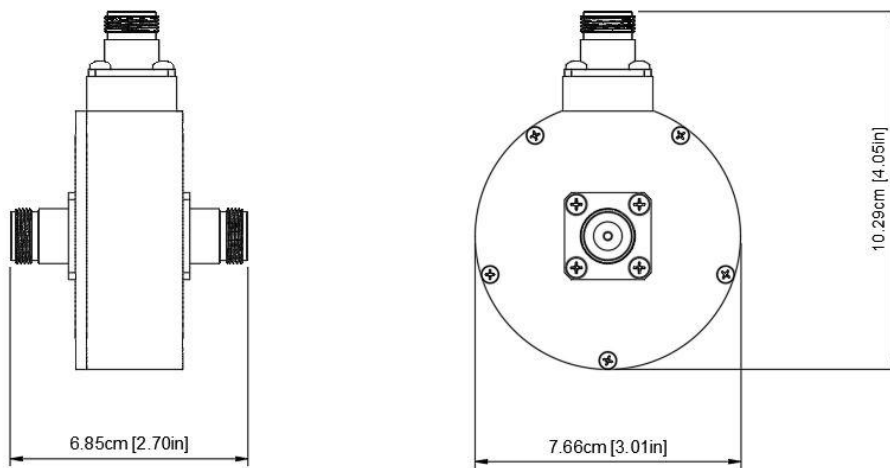

TBCCP1-2K70 coaxial RF current monitoring probe dimensions

3. Antenna conversion factor

To determine the conversion factor of the TBRE101 receiving loop, subtract the calculated magnetic flux density (in dBpT) from the TBRS101 radiating loop in 12 cm distance from the RFoutput voltage of the TBRE101 loop (in dBμV) measured with a 50 Ohm/High impedance measurement instrument.

The generated magnetic flux density from the TBRS101 radiating loop and the output voltage of the TBRE101 loop must be measured as a function of frequency in the range of 30 Hz to 100 KHz using the TBRE101 Antenna Conversion Factors Table from Chapter 4.

30 Hz – 100 KHz RE101 Loop Antenna

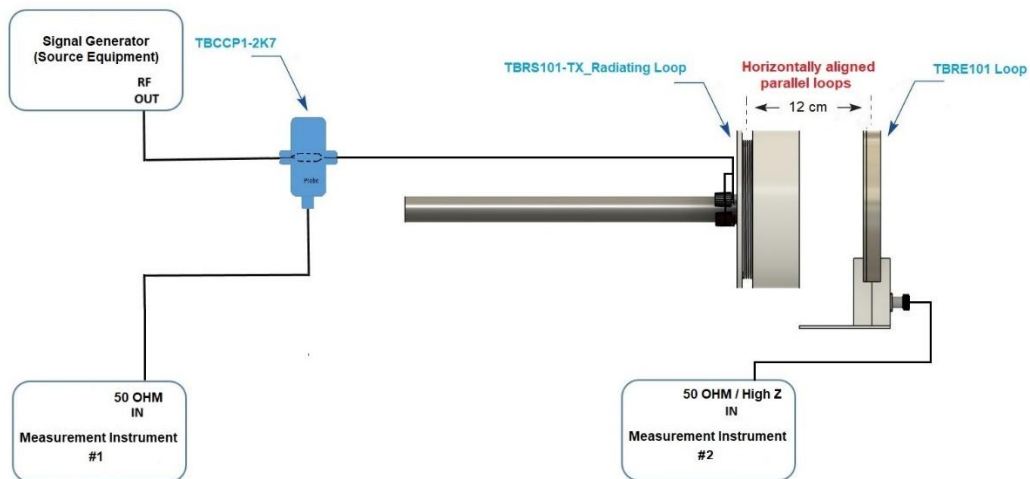

TBRE101 Typical Calibration Setup (RF Current Probe Method)

The conversion factor is given in two formats (dB μ V to dBpT) and (dB μ V to dB μ A/m) as the former is 1.98 dB higher than the latter. The observed antenna conversion factors are valid if they are within ± 3 dB of the theoretical MIL-STD-461G RE101 loop conversion factors over the frequency range 30 Hz to 100 kHz.

Applying the antenna conversion factors converts the measured voltage at the TBRE101 output (in dB μ V) to the magnetic flux density (in dBpT) and the magnetic field strength (in dB μ A/m) respectively. The magnetic flux density values (in dBpT) are considered as the level of radiated disturbance from the EUT, which are then compared against the radiated emissions limits of MIL-STD-461G RE101.

Below are the equations used to calculate the radiated disturbance level:

$$\text{Magnetic Flux Density (in dBpT)} = \text{Measured Voltage (in dB}\mu\text{V)} + \text{Antenna Conversion Factor (in dBpT}/\mu\text{V)}$$

$$\text{Magnetic Field Strength (in dB}\mu\text{A/m)} = \text{Measured Voltage (in dB}\mu\text{V)} + \text{Antenna Conversion Factor (in dB}\mu\text{A/m}/\mu\text{V)}$$

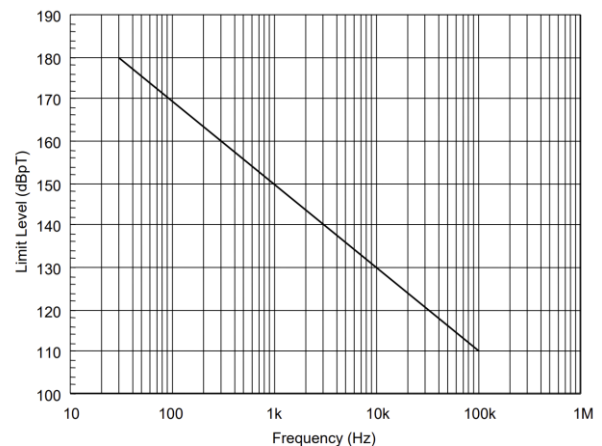
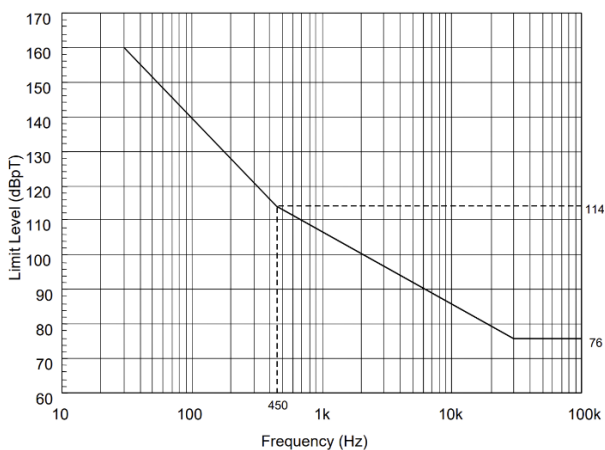

RE101 limits for all Navy & Army applications

30 Hz – 100 KHz RE101 Loop Antenna

4. TBRE101 Antenna Conversion Factors

Frequency	TBRE101 Conversion	TBRE101 Conversion	MIL-STD-461G Conversion
[KHz]	[dB μ V to dBpT]	[dB μ V to dB μ A/m]	[dB μ V to dBpT]
0.01	82.45	80.47	91.6
0.02	83.62	81.64	85.7
0.03	81.58	79.60	82.1
0.05	79.75	77.77	77.7
0.1	72.82	70.84	71.7
0.2	66.95	64.97	65.6
0.3	63.91	61.93	62.2
0.5	59.66	57.68	57.7
1	53.86	51.88	51.7
2	47.99	46.01	45.7
3	44.53	42.55	42.2
5	40.17	38.19	37.8
10	34.49	32.51	32.2
20	29.83	27.85	27.4
30	27.84	25.86	25.4
50	26.05	24.07	23.9
100	25.14	23.16	23
200	24.71	22.73	22.8
300	24.38	22.40	22.7
500	23.28	21.30	22.7
1,000	16.26	14.28	22.7

Typical Antenna Conversion Factors Table (50 Ohm Load Impedance)

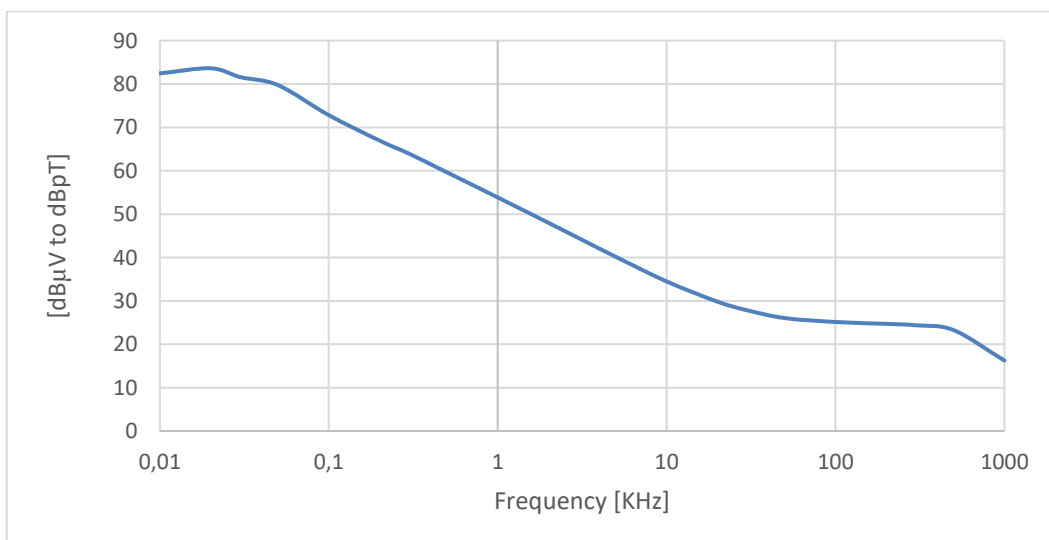

TBRE101 Typical Antenna Conversion Factor (50 Ohm Load Impedance)

30 Hz – 100 KHz RE101 Loop Antenna

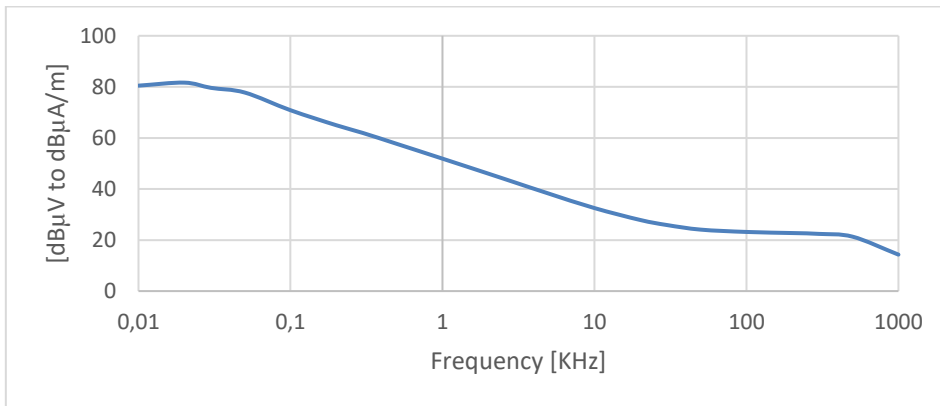

TBRE101 Typical Antenna Conversion Factor (50 Ohm Load Impedance)

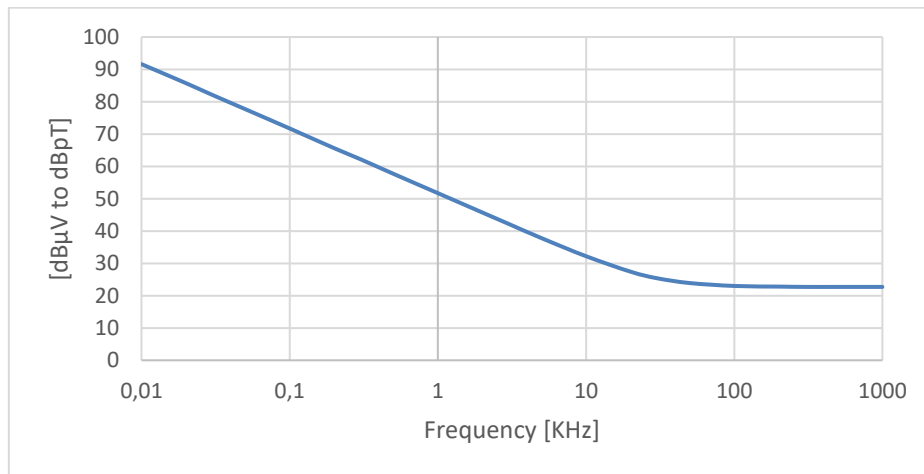

MIL-STD-461G RE101 Loop Antenna Conversion Factor (50 Ohm Load Impedance)

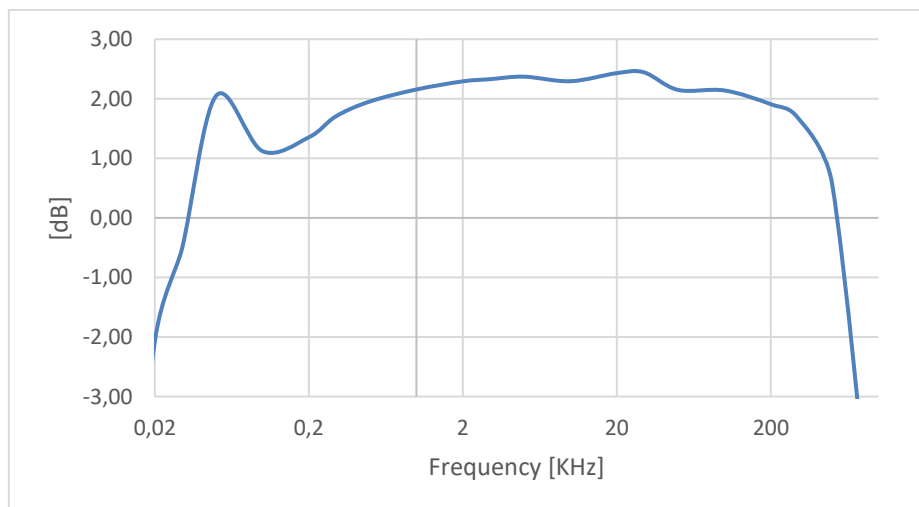

Deviation from MIL-STD-461G RE101 Loop Antenna Conversion Factor (50 Ohm Load Impedance)

30 Hz – 100 KHz RE101 Loop Antenna

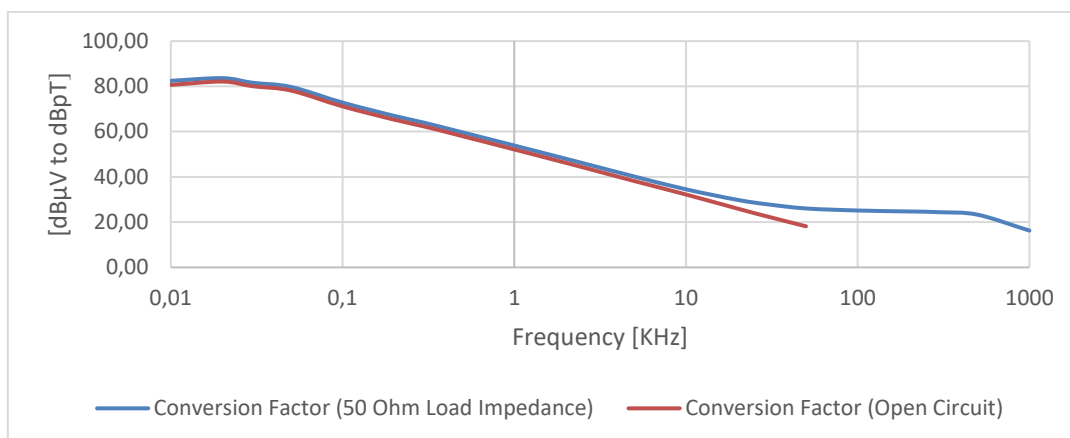

TBRE101 Typical Antenna Conversion Factor (50 Ohm Load Impedance vs Open Circuit)

5. Calibration

The TBRE101 comes with a factory calibration protocol. Optional calibration accessories include the TekBox TBRS101 radiating loop and its threaded mounting pole, the TekBox TBCCP1-2K70 coaxial RF current monitoring probe (transducer), a 50 Ohm RF terminator, a BNC Female to 4mm Banana Plug, and interconnecting cables, which allow for periodic re-calibration or validation of performance as needed.

The calibration process for measuring system integrity is described in chapter 5.17.3.4 of the MIL-STD-461G standard.

6. Ordering Information

Part Number	Description
TBRE101 Loop Antenna	30 Hz – 100 KHz loop antenna factory calibration report, user manual

Accessories

Part Number	Description
TBRS101-TX Radiating Loop	Radiating loop for generating magnetic fields in the range of 30 Hz to 100 KHz
TBCCP1-2K7	Coaxial RF current monitoring probe for measuring the injected current into the radiating loop
TBMR-110M	1Hz – 110 MHz measurement receiver, CISPR 16 and MIL-STD-461

7. History

Version	Date	Author	Changes
V1.0	7.2.2025	Mayerhofer	Creation of the document

TekBox Digital Solutions Vietnam Pte. Ltd.

www.tekbox.com

Factory 4, F4, Lot I-3B-1, Saigon Hi-Tech Park, Tan Phu Ward, District 9, Ho Chi Minh City, Vietnam